

# MACHINEX

- AFTER SALE SUPPORT 24/7
- REMOTE ASSISTANCE
- MANUAL CHAGE OVER TOOL FREE
- CHANGE OVER TIME UP TO 20 MINUTES FOR ONE TRAINED OPERATOR

## ASTERON

### RSC CASE PACKER

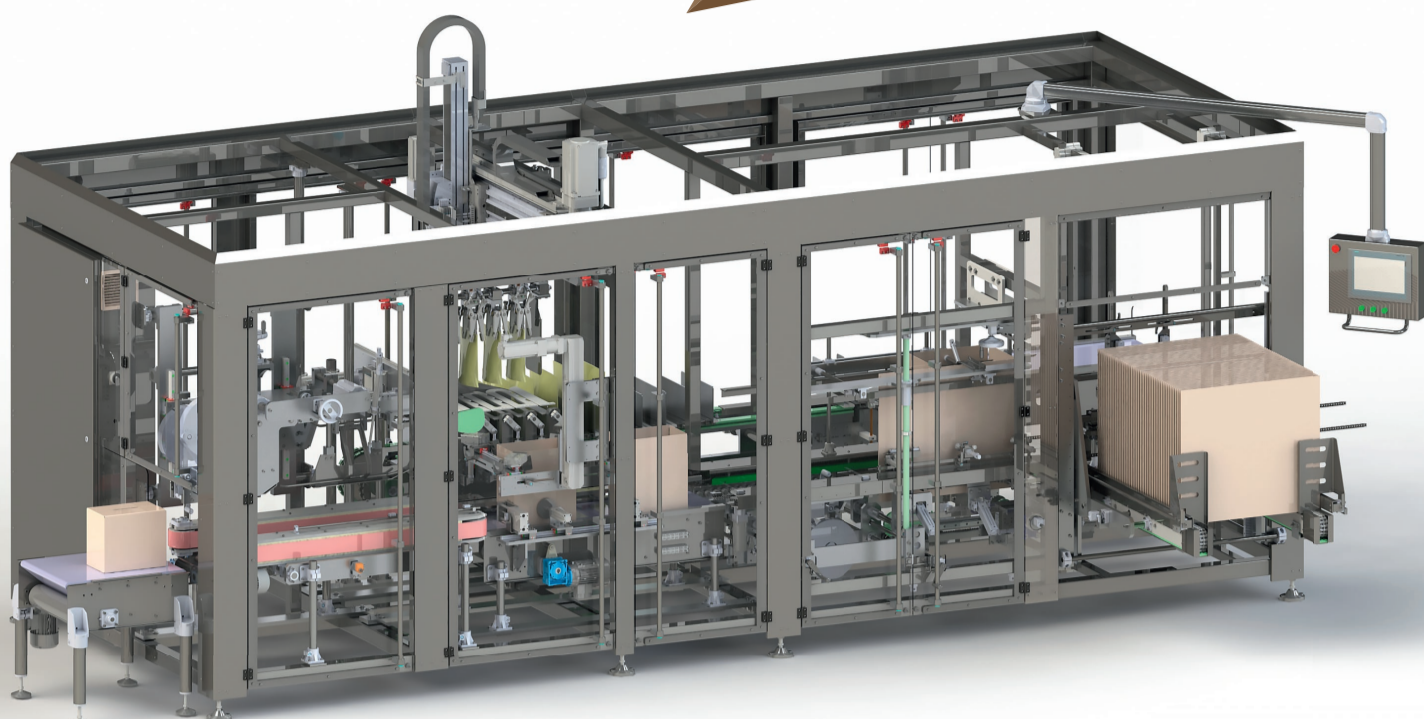

REMOTE ASSISTANCE

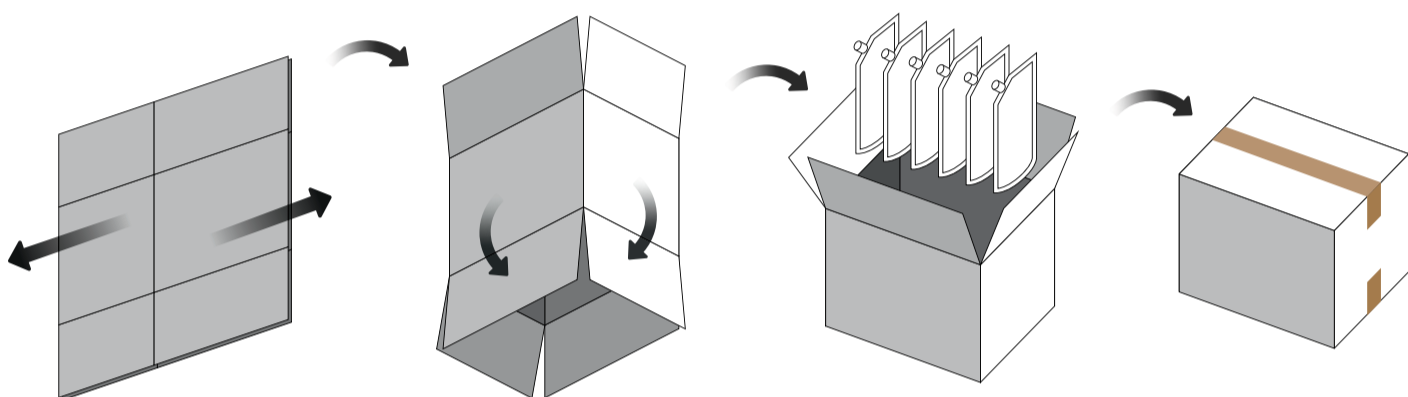

### ASTERON

Monoblock design for case erecting, products loading in RSC cases, case closing and flaps sealing.

Products incoming section, inlet module for loading formation preparing will be constructed by the actual situation, speed, lay out and other relevant characteristics of products and environment.

Reliable Machinex design provides RSC case formed on 90 degrees, product control and safe loading.

**ASTERON** system can be top load or side load solution, depending on the products incoming and position in the case. Also, ASTERON can be tape sealing or hot melt solution (as well as bottom flaps tape and top flaps hot melt sealing, or vice versa).

**ASTERON** system is manually adjustable for different cases or products dimensions.

Change over time 20 minutes.

Automatic change over upon request.

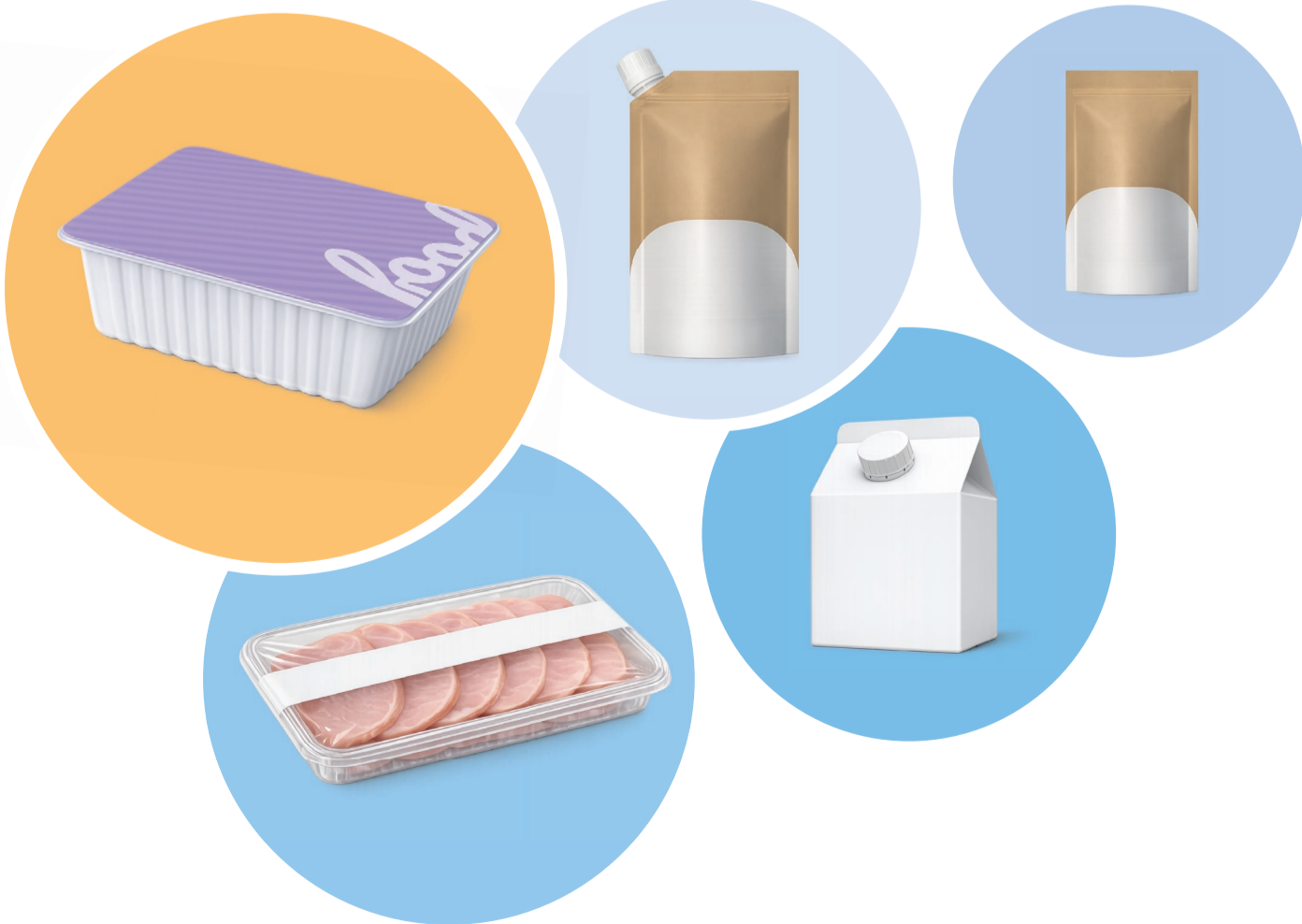
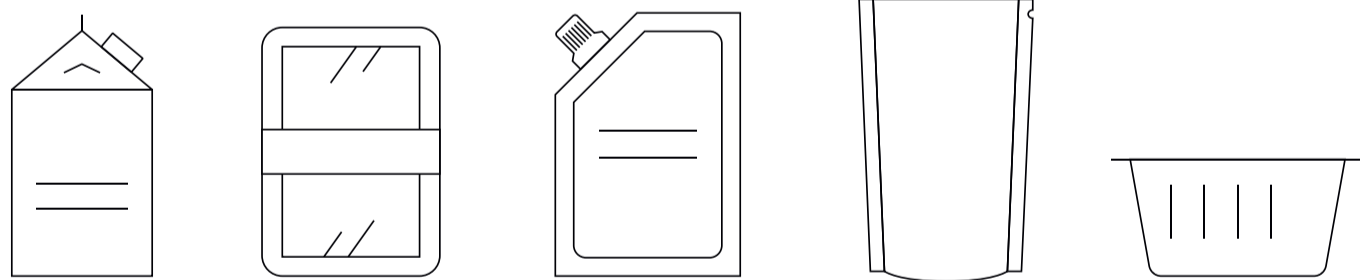

Slovenski put 6A, 35000 Jagodina – Serbia



Mobile: +381 63 641 511 • Office: +381 35 241 600 • Fax: +381 35 241 600  
Email: info@machinex.rs • Website: <https://machinex.rs/>